

Neater Eater Instruction Manual

Providing equipment for greater
independence, dignity and choice



- Read all instructions carefully before use and particularly before making any adjustments. Incorrect use and adjustment could damage the Neater Eater and/or make its use dangerous in some way.
- The Neater Eater should not be used by people with swallowing difficulties or who are liable to choke, except under the supervision of a Speech and Language Therapist.
- Ensure the Neater Eater is firmly attached to a sturdy table to avoid it overbalancing.
- People with uncontrolled movements, particularly uncontrolled body or head movements, should not use hard or sharp cutlery such as metal spoons or forks.

Further Health and Safety

- The Neater Eater should only be used to assist the eating of consumable foods or for holding safe light objects. Ensure that food is not scalding hot.
- Do not attempt to eat large amounts of food in one mouthful as this can lead to choking.
- A carer should always be present if there is any risk of choking or any other danger.
- Clean all parts before every meal and check there are no cracks or chips. Most plastic cutlery will crack eventually, ceramic plates can chip creating sharp edges and should be replaced.
- Before each meal, check that the peg on the base of the plate is firmly attached.
- Only use attachments supplied by authorized Neater Eater distributors.
- Take care not to stick the cutlery in your eye or into the back of your throat.
- Ensure all stops are properly adjusted as appropriate before use.
- Be careful not to hit the clamps when moving into position to use the Neater Eater.
- Wipe the Neater Eater clean after each meal to stop any build up of food which can collect germs and could also get into and damage the mechanism of the Neater Eater. Ensure crockery and cutlery are properly cleaned.
- Crockery and cutlery provided with the Neater Eater are food safe. Other components may not be safe to suck or chew.
- Side effects of using the Neater Eater may include over-eating, fatigue or muscle build-up through the exercise involved. Advice should be sought as appropriate e.g.: from a dietician and a physiotherapist.

Neater Eaters are designed to comply with the essential requirements of the Medical Devices Directive Class 1 (EC Council Directive 93-52-EEC of 14 June 1993).

Contents



User Safety

2



Overview

4



Adaptations

6

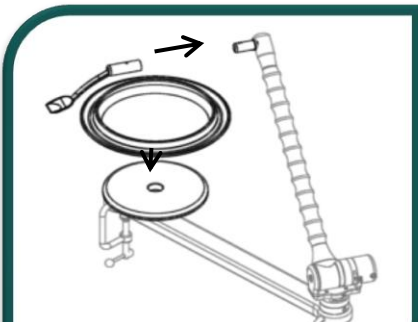

Quick Set Up

8

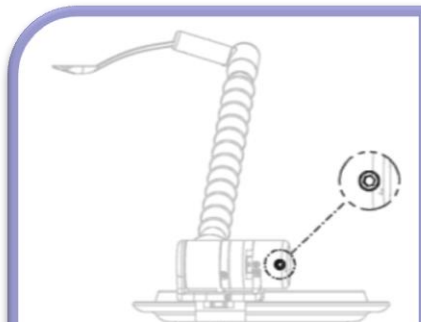

Further Adjustments

10

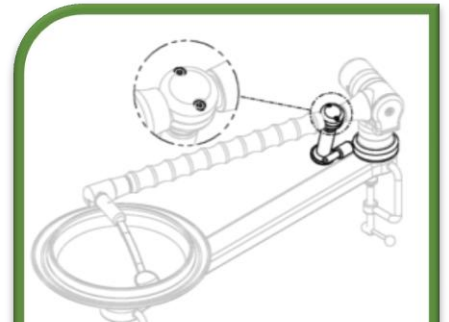
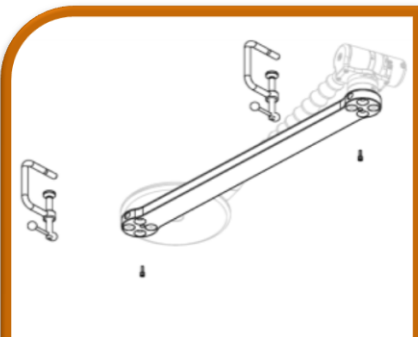

Plate Flick Guard

12



Fitting Adaptations

13



Hints and tips

14



Maintenance

15

Video instructions are available online: www.neater.co.uk



Our products are developed and manufactured in the UK



Compliant with EU medical devices directives and supplied worldwide.

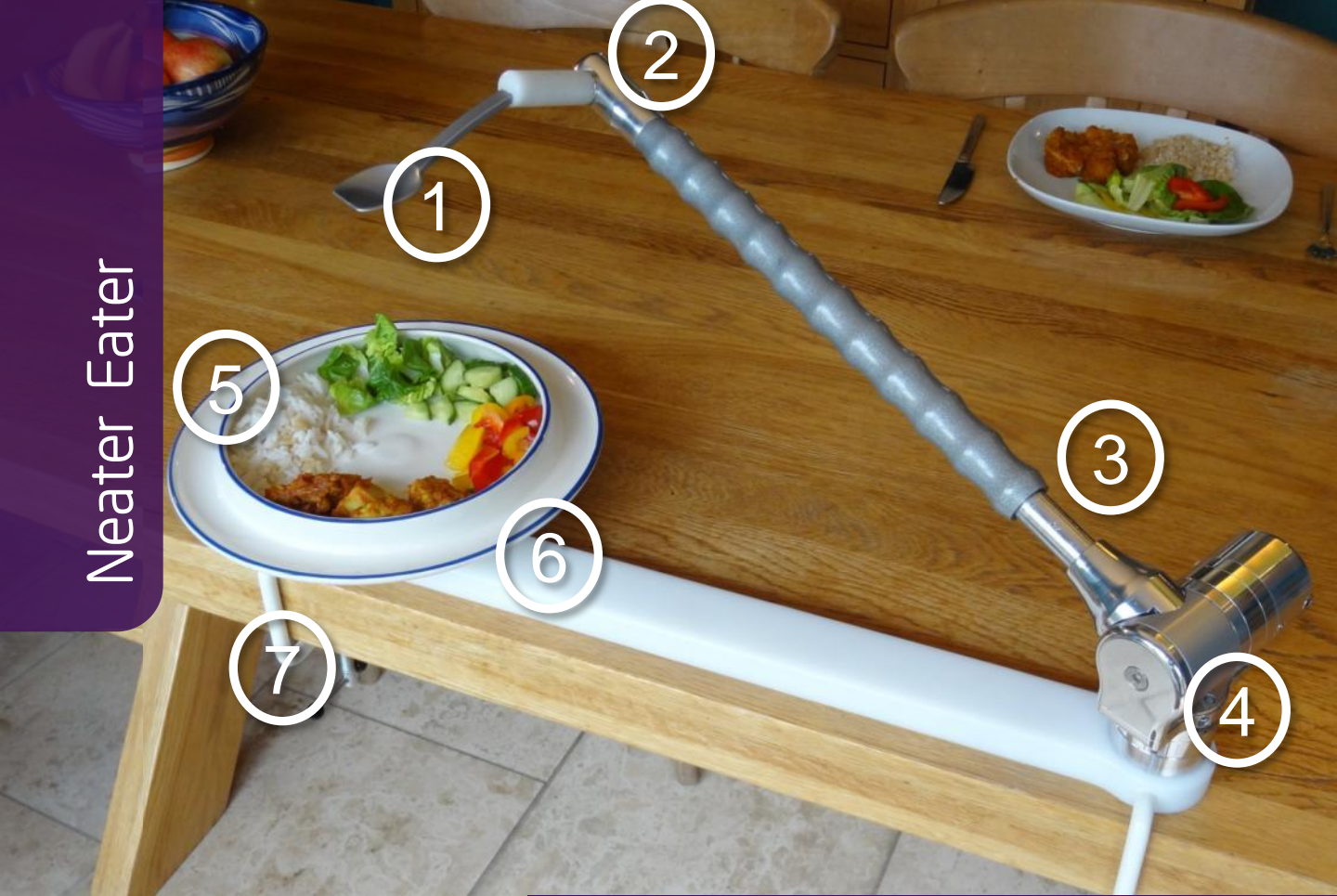

Overview

A modular system, the Neater Eater® is designed to enable people to use their own movements to feed themselves.

.....
* **Viscous Damping**, a thick liquid allows slow smooth movement but absorbs fast movement and tremor

- ① Scooping action – clip-on spoon tilts up and down with the arm
- ② Spoon automatically remains level at all times
- ③ Tremor or ataxia absorbed by viscous fluid damping*, this is adjustable
- ④ Lifting assisted by internal springs. Height and speed easily adjusted
- ⑤ Scooping of food assisted by shaped plate lip
- ⑥ Plate secured in the baseboard. It is turned to reach the food
- ⑦ The Neater Eater is secured to the table with clamps

"The Neater Eater is an invaluable piece of equipment in maintaining someone's independence and self-esteem."



"It gives me the independence to eat with confidence and dignity. I love the sleek design; it's really cool."

For info on other products please visit:

The logo for Neater.co.uk features a stylized white outline of a robotic arm or hand reaching upwards, followed by the text "Neater.co.uk" in a white, sans-serif font.

Wheelchair accessible
Neater Table



Touch controlled Neater
Eater Robotic



A range of Neater Drinkers

For our latest product information please contact us:



+44 1 298 238823



info@neater.co.uk



www.neater.co.uk

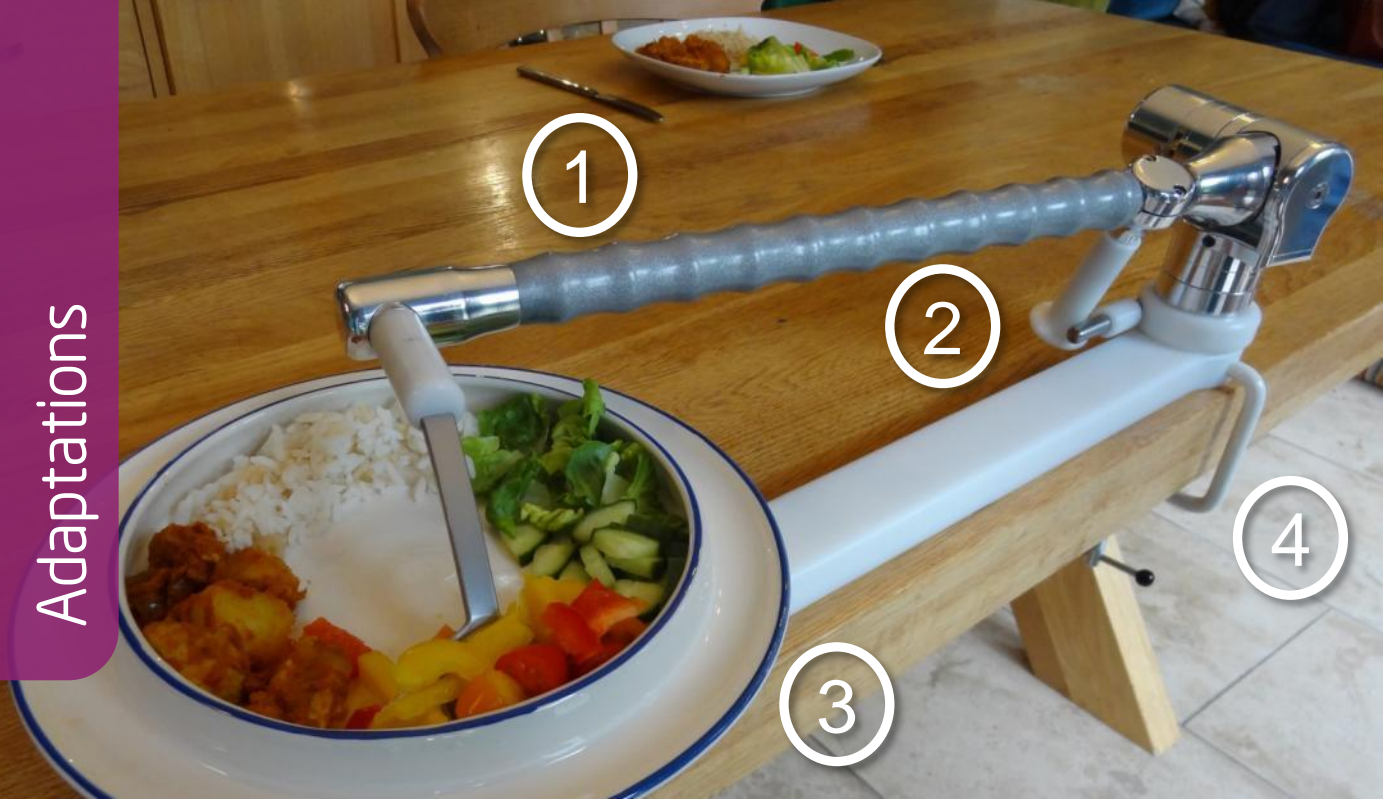

Modular system – adaptations

The Neater Eater is a modular system. Different attachments and settings are suitable for people with different abilities.

Latest information:
www.neater.co.uk

Cutlery

A range of sizes and materials to suit individual needs:

- Stainless steel: spoons, fork and Spork
- We recommend the **Neater Spoon**; it is ideally shaped for scooping and quite soft and kind to your mouth

- ① Neater Eaters are available **RIGHT** or **LEFT** handed
- ② **PLATE FLICK GUARD** stops spoon from spilling food at edge of plate
- ③ **PLATE HOLDER** fitted in different positions for accessibility
- ④ **CLAMPS** standard, compact, large



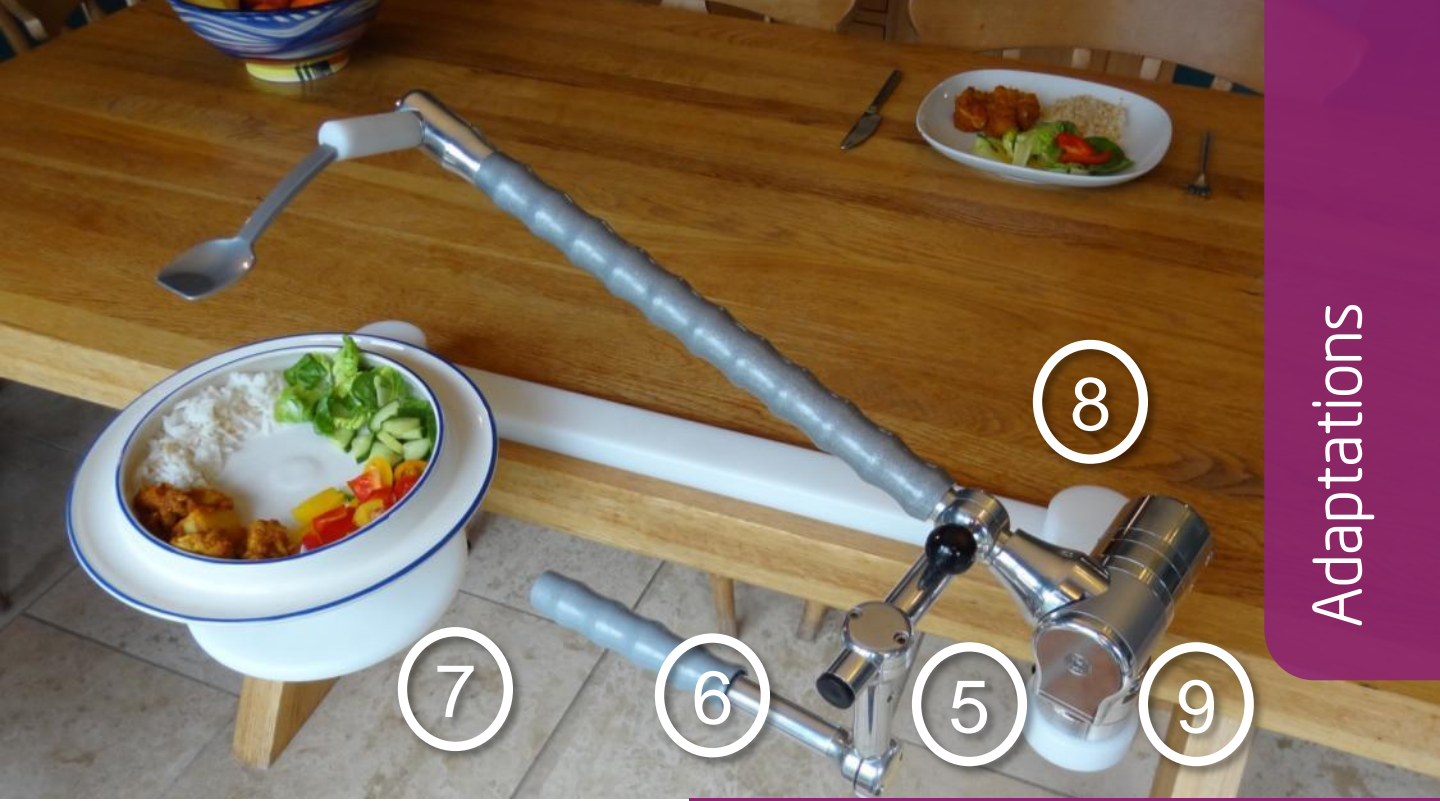

⑤ **RAISING SPACERS** raise the arm and/or the plate for accessibility.

⑥ Quick Release **ADJUSTABLE HANDLE** enables easy use

⑦ **PLATE TURNER** allows plate turning without lifting your hand from your lap

⑧ **EXTENDED BASEBOARD ARMS** for accessibility

⑨ **FORWARD SPRING** brings the spoon to your mouth automatically

Crockery

Choices include:

- Large and small ceramic plates
- Plastic plates
- Heated ceramic plate
- Soup bowl
- Plate stands



Step 1:

Fold out the **Clamps** and attach to your table

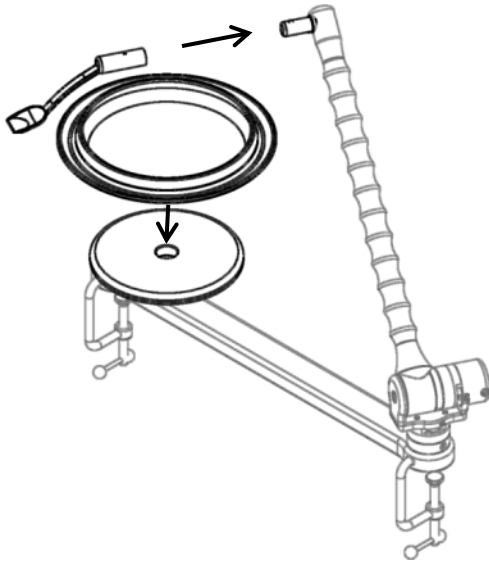
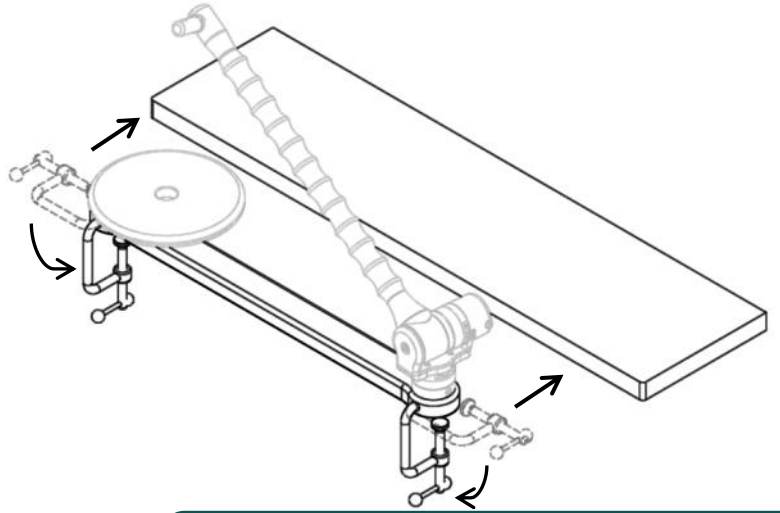

Step 2: Attach crockery and cutlery

Push the **Spoon** on ; it clicks into place. The peg on the bottom of the **Plate** goes into the hole in the baseboard

Step 3: Position yourself

Sit quite close to the Neater Eater and adjust so that the spoon comes to meet your mouth. **Correct alignment is important.**

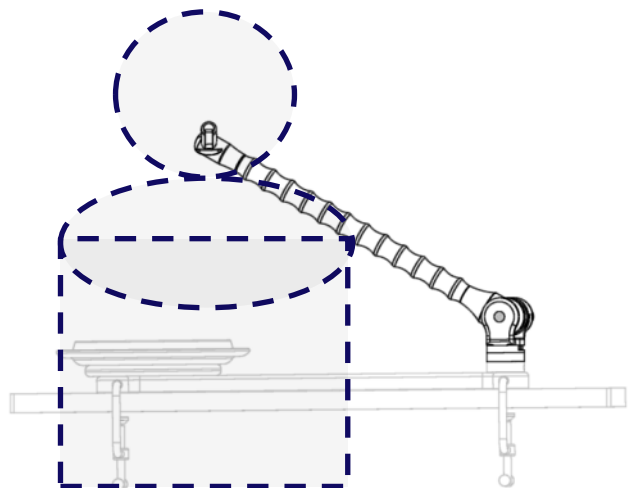
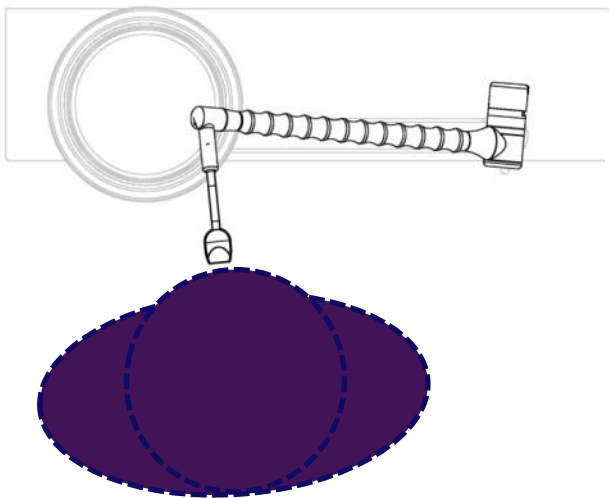

Step 4: Adjusting the stops

To adjust the stops, simply screw the stops in or out turning the small Allen key.

The **Up Stop** and **Forward Stop** should be adjusted so that the spoon reaches your mouth.

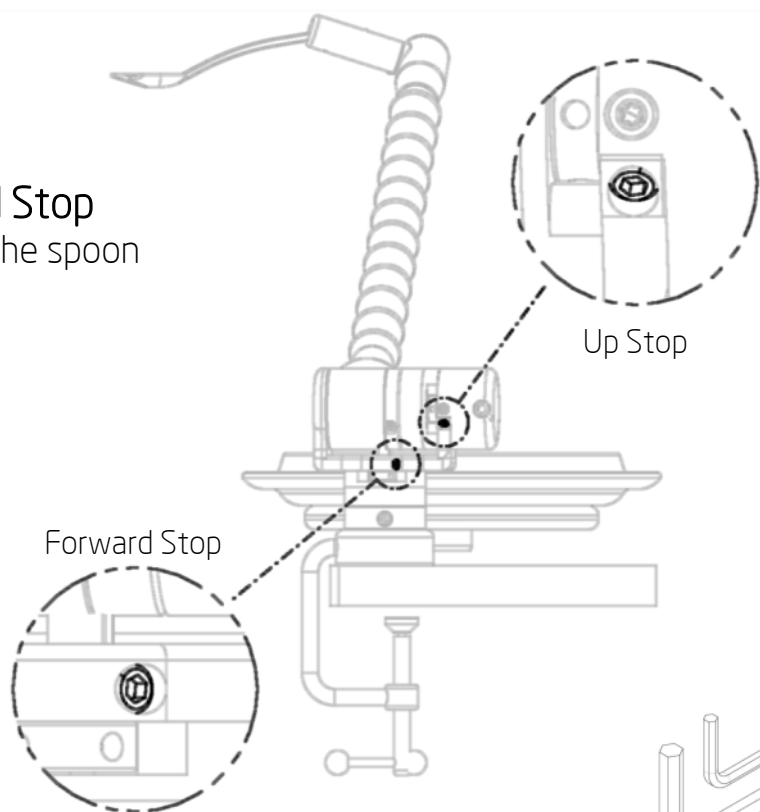

Quick set up

Please read [Hints and Tips](#) section page 14
Enjoy your meal

Further Stops

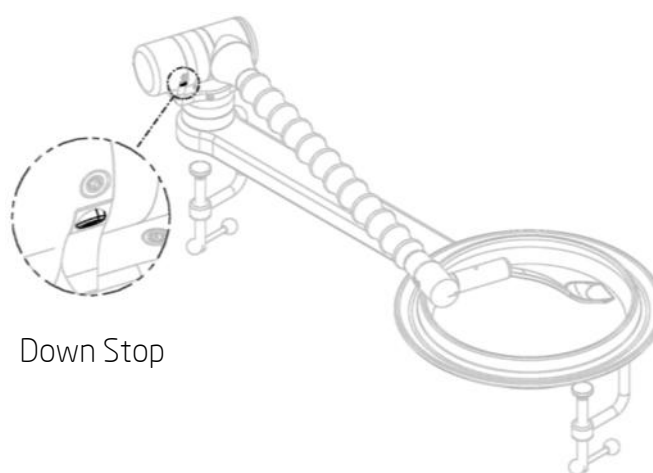

The **Down Stop** is usually pre set so that the spoon goes into the plate far enough for scooping without bending up.

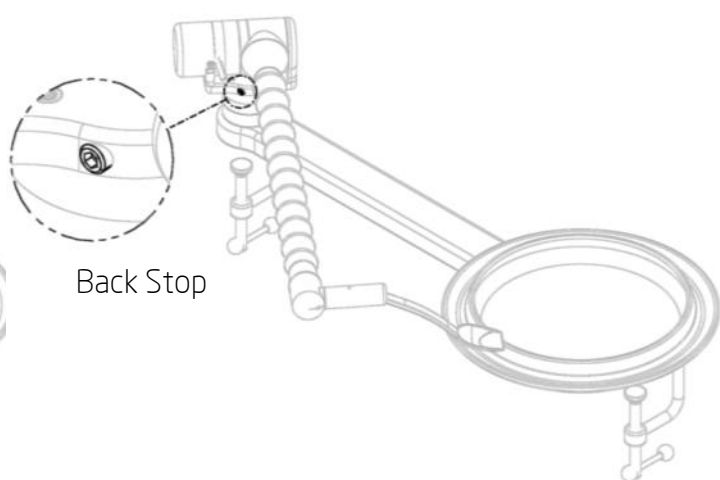

The **Back Stop** is usually pre set to allow wiping the spoon against the back of the plate but not getting caught behind the plate.

Further Adjustments

- Increase **Damping Levels** to absorb tremor.
- Decrease to ease movement.
- Use the small Allen key as a lever to turn both damper adjusting wheels.
- The arm needs to be moved backwards and forwards and up and down a few times before the damping level settles.

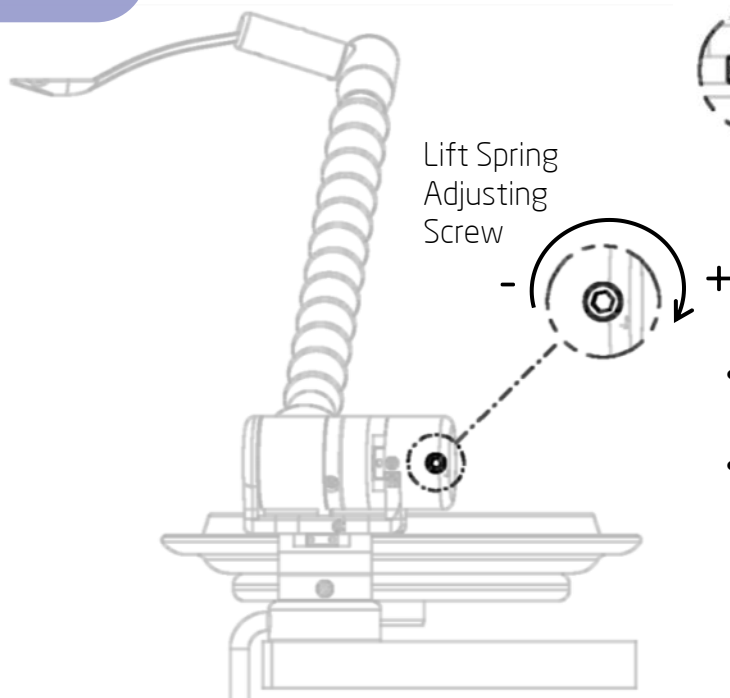
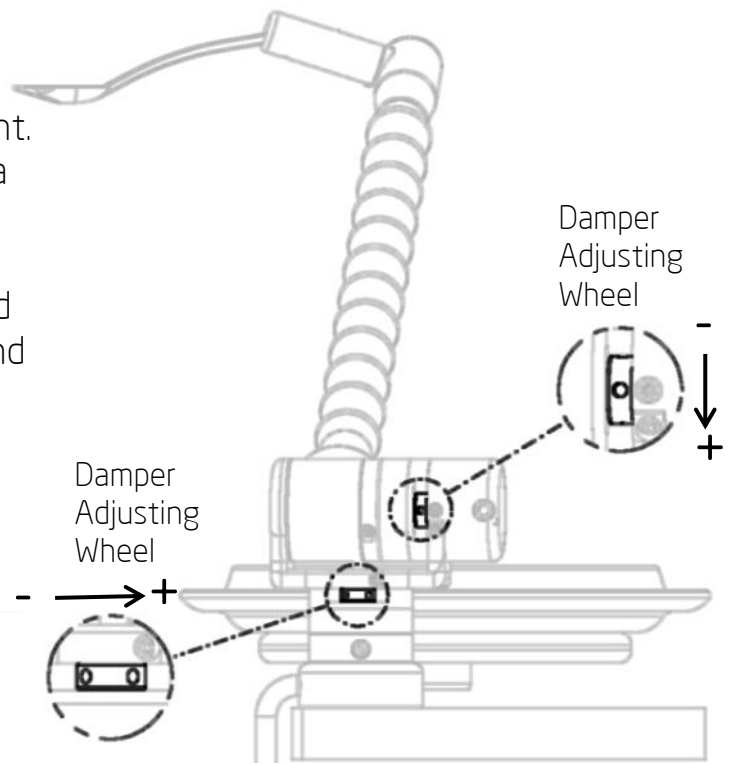

- Adjust the **Lift Spring** to lift the arm faster or slower.
- Turn the adjusting screw several turns with the large Allen key.

If a **Forward Spring** is fitted it is usually adjusted so that the spoon finishes coming forwards after it has finished lifting up. To adjust:

- Bring the arm forwards
- Carefully loosen the screw in the top part of the forward spring attachment, **taking care not to allow the top part to rotate quickly and throw the Allen key!**
- Rotate this top part to change the tension in the spring
- Retighten the screw.

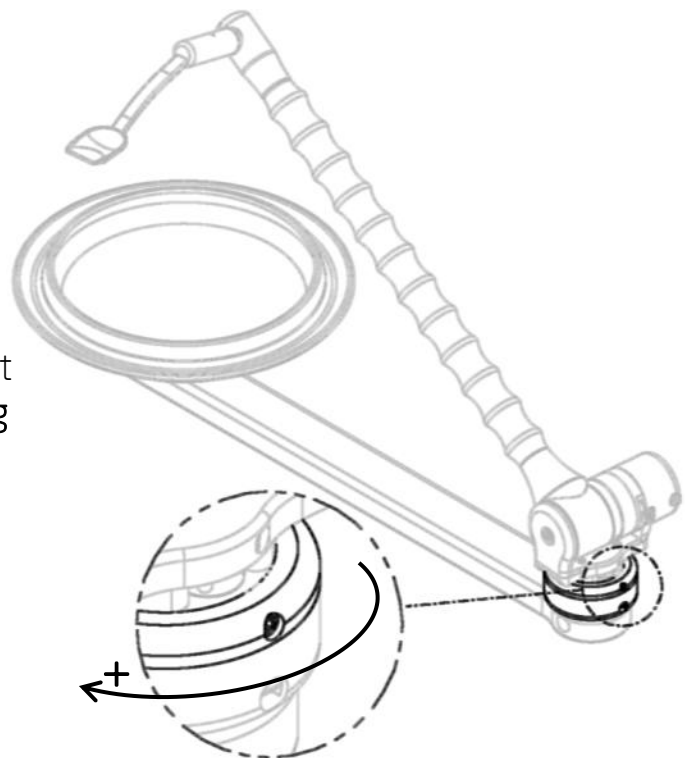

Adjustable Handle allows easy reach for using the Neater Eater

To Remove: Unscrew ball knob just one or two turns and slide off handle.

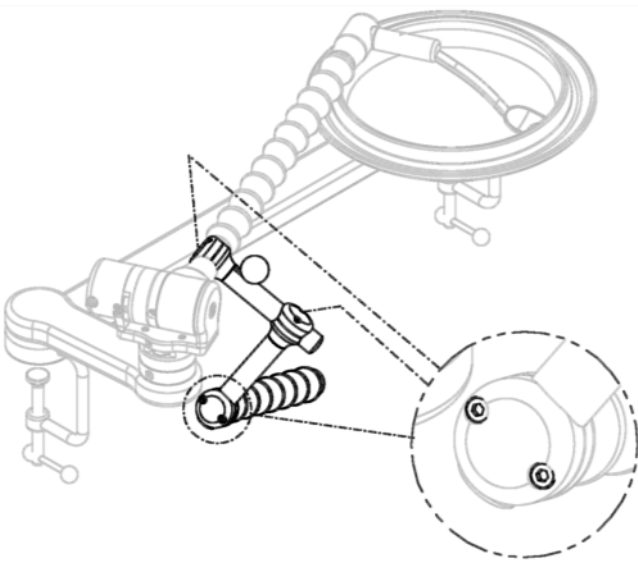
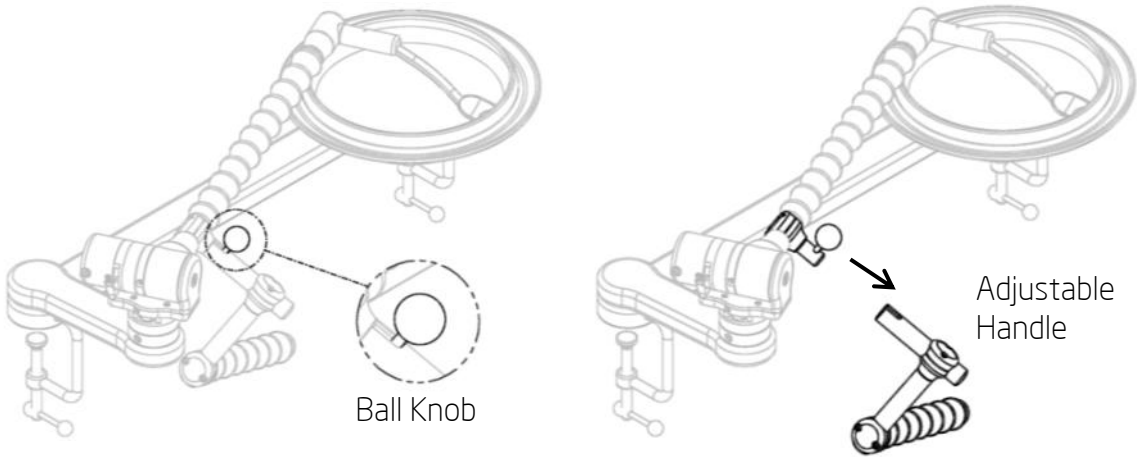

Adjust Handle Position

- Loosen both screws in the top of any bracket slightly
- Slide and rotate the bracket and handle into the desired position
- Retighten screws.

Plate Orientation

The plate-holder part of the baseboard can be brought forward to improve accessibility. Remove the 2 screws holding it in place, rotate it and refit the screws through the other 2 holes in the long part of the baseboard.

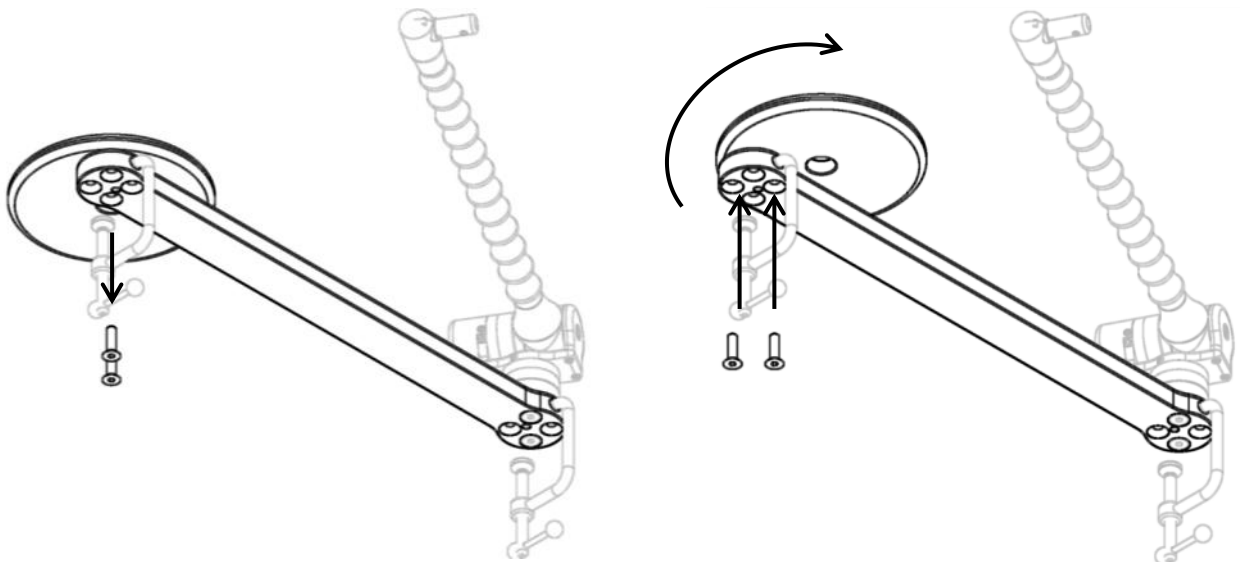
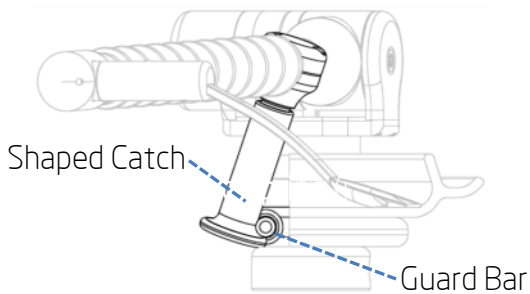
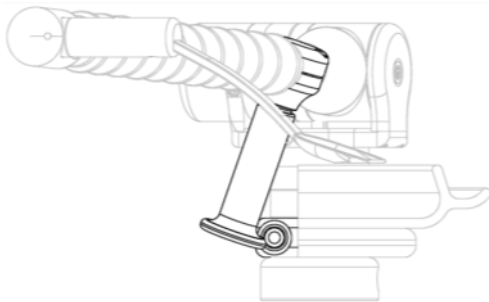

Plate flick guard stops spoon from spilling food at edge of plate.



- Shaped catch engages with guard bar as spoon is brought forward towards the edge of plate
- Here the spoon cannot be lifted and flick food



- The spoon is made to move back as it is lifted missing the plate edge

- Once clear of the plate, the spoon can be brought to your mouth

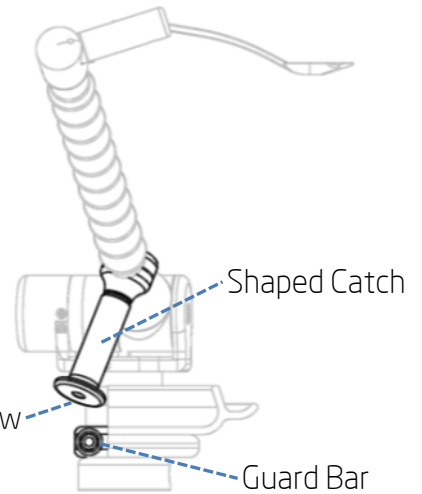

- The plate flick guard can be set for use with two plates
- When using the smaller plate, simply slide the **slider** into position to engage with the shaped catch.

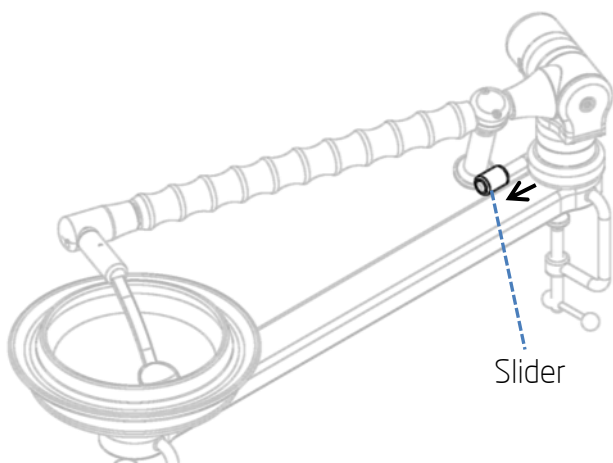

Different plates may require adjustment of:

- The angle of the shaped catch (loosen bracket screws, adjust angle, retighten screws)
- The length of the shaped catch (loosen locking screw inside the shaped catch, rotate shaped catch to length or shorten, retighten locking screw)

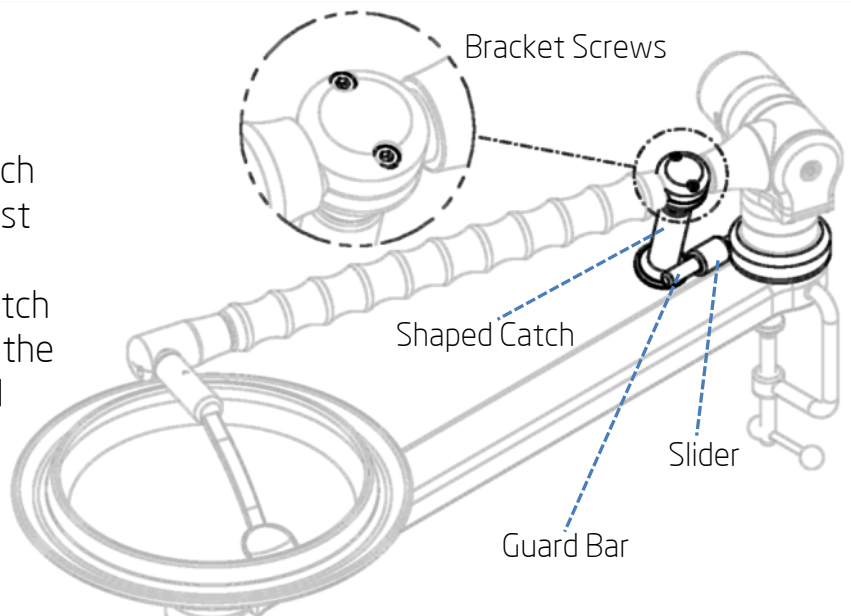

Clamp Replacement

- Different size clamps can be fitted: Large, Standard and Compact.
- Clamps are held in by screws and plastic washers underneath.

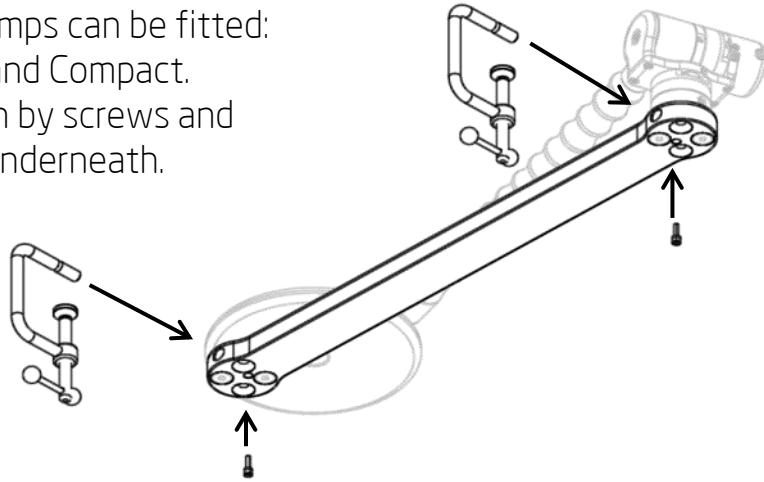

Fitting adaptations

Baseboard modular components

- Screws are removed and replaced with longer screws to fit different adaptations.
- Some holes are positioned to angle the extensions so that spoon lines up with the edge of the plate

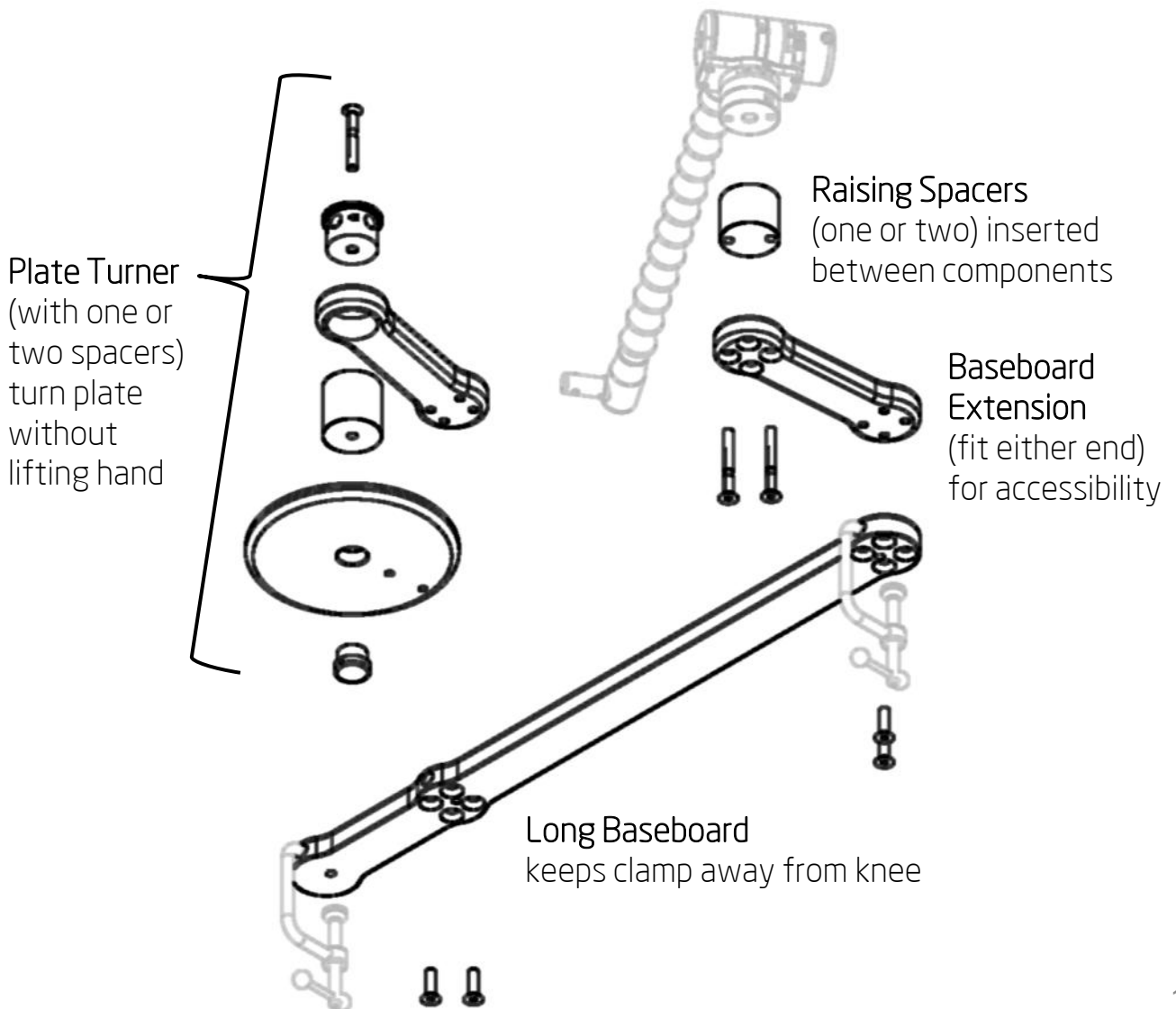



Correct positioning is vital

- Sit close to the plate.
- Ensure your mouth is aligned with the spoon. (See quick set-up instructions)
- Some people like the spoon to stop a little in front of their mouths.
- Others (particularly people with head tremor) may need the spoon to come up to mouth level and then move forward all the way into their mouth.

First use and avoiding mess

- Start with less food in the plate.
- Start with food of even consistency
- Place food around the outside edge of the plate.
- Chop food into chewable sized pieces
- Remember, we can all be a little messy when eating!

Scooping food

- Push the arm back and down so the spoon sits in the middle of the plate.
- Keep the spoon down and bring it forward scooping food against the edge of the plate.

Avoid flicking

- Push back away from edge of plate as you lift the spoon to avoid flicking.
- A Plate Flick Guard attachment is available



Drips

- Drips can be wiped off the bottom of the spoon against the back edge of the plate.
- Hold the spoon over the plate for a few seconds to allow excess food to fall off before bringing it to your mouth.

Turn the plate

- Turn the plate to select new food.
- It is held securely.
- Experiment with different ways of turning it.

Scrape the plate at the end of the meal

- When there is very little food left, bring the spoon forwards to the front of the plate and turn the plate all the way round creating a pile of food you can then scoop.

Maintenance and Cleaning

- The Neater Eater is designed for a long maintenance-free life as long as it is kept clean.
- Wipe with a damp cloth and a little detergent to remove food deposits.
- Do not immerse the Neater Eater in water.
- The plate and spoon can be washed in a dishwasher; on the top rack or away from the heating element.
- Washing by hand will prolong the use of the plastic plates and spoons.

If you have a problem:

- Please do not try dismantling your Neater Eater!
- Get in touch with us:



info@neater.co.uk



+44 1 298 238823



www.neater.co.uk

Neater Solutions Ltd

12 Burlington Road,
Buxton,
Derbyshire,
SK17 9AL

Tel: + 44 (0) 1298 238823

Email: info@neater.co.uk

www.neater.co.uk



Specifications subject to change without notice, patents applied for.